

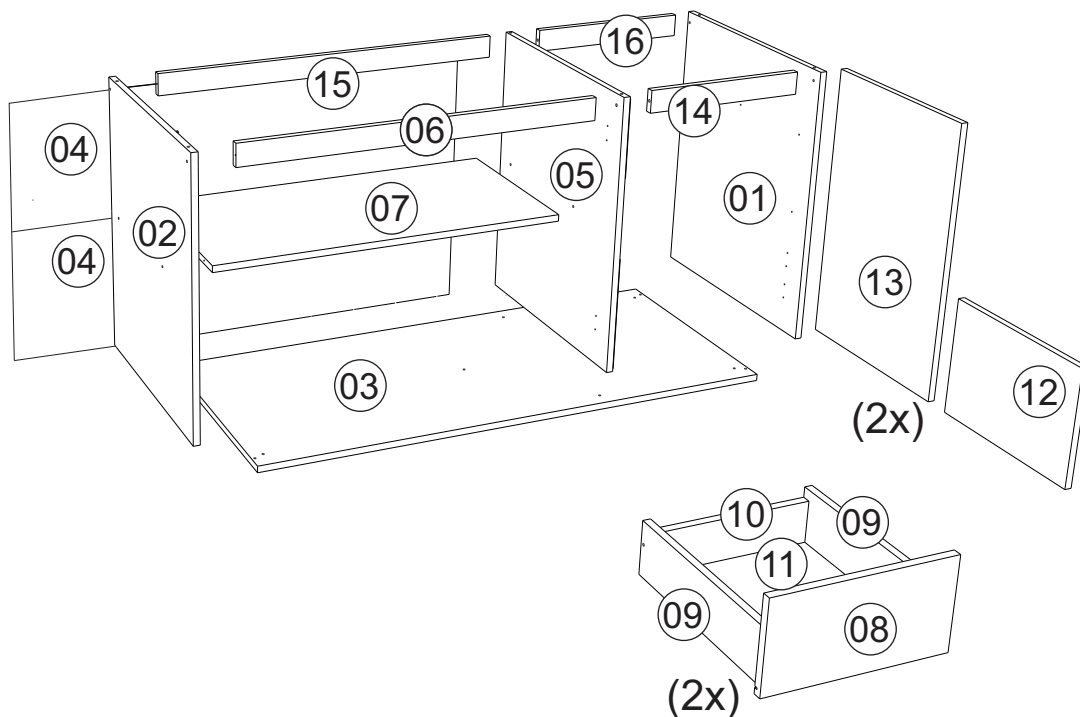

Rodovia SC-492 - Km 10 - B. Industrial
89905-000 - Bandeirante - SC
Fone: (49) 3622-4549
e-mail: mxmoveis@mxmoveis.com.br

Ref. BGL02

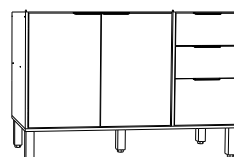

Balcão 1200 2P 3G
Balcón 1200
Counter 1200
Cozinha/Cocina
GLORIA



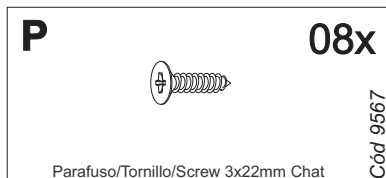
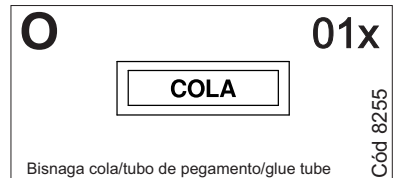
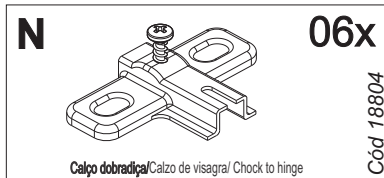
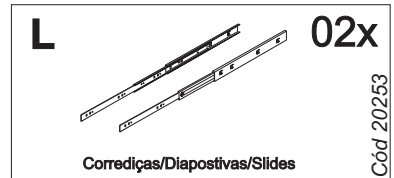
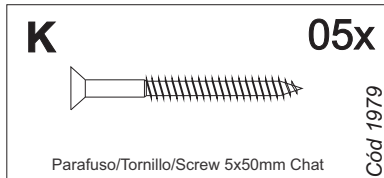
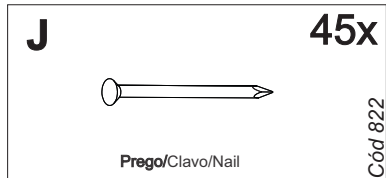
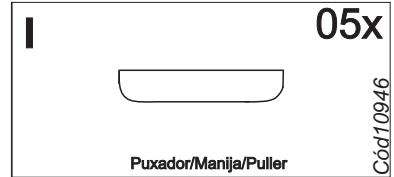
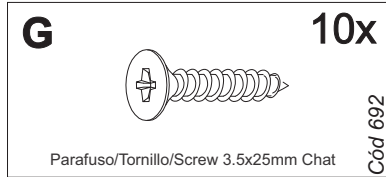
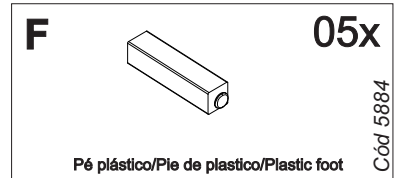
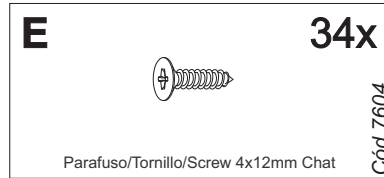
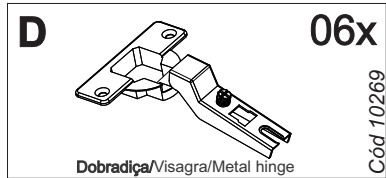
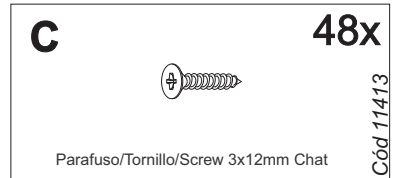
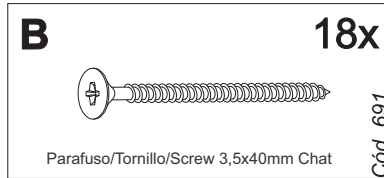
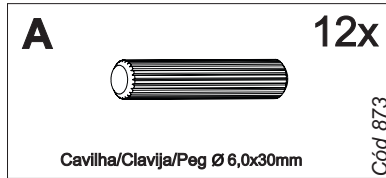

Nº	CÓDIGO CODE ASSISTÊNCIA ATTENDANCE	NOME DA PEÇA/DESCRIPCIÓN PIEZAS/DESCRIPTION PARTS	MEDIDAS (mm) MEASURES (mm)	QTD.	CASTANHO CASTANHO	BRANCO NEVE BRANCO NEVE
01	BGL02.17.00	Lateral externa direita/Lateral derecha/Right side	625x516x15	01	263565	277514
02	BGL02.18.00	Lateral externa esquerda/Lateral izquierda/Left side	625x516x15	01	263785	277515
03	BGL02.01.00	Base inferior/Base/Shelf	1200x516x15	01	263564	277512
04	BGL02.13.00	Forro/Revés/botton	1186x300x2.5	02	260772	260772
05	BGL02.19.00	Lateral interna/Lateral interna/Inner side	625x516x15	01	264561	277516
06	BGL02.28.00	Ripa sustentação frontal /Travesaño/front support slat	795x50x15	01	263568	277519
07	BGL02.02.00	Base interna/Base pequena/Shelf	795x387x15	01	261607	261607
08	BGL02.14.00	Frente gaveta/Frente cajón/Drawer front	352x175x15	02	260905	277513
09	BGL02.15.00	Lateral gaveta/Lateral cajón/ Drawer side	350x100x15	04	260777	260777
10	BGL02.29.00	Ripa Traseira de gaveta/Trasero cajón/Drawer back	306x80x15	02	260785	260785
11	BGL02.34.00	Forro gaveta/Revés cajón/Botton	355x336x15	02	260773	260773
12	BGL02.25.01	Porta/Puerta/Door	352x255x15	01	260910	277518
13	BGL02.25.00	Porta/Puerta/Door	615x392x15	02	260909	277517
14	BGL02.28.02	Ripa sustentação frontal /Travesaño/front support slat	360x50x15	01	263786	277520
15	BGL02.28.01	Ripa sustentação /Travesaño/Rear support slat	795x50x15	01	260784	260784
16	BGL02.28.03	Ripa sustentação /Travesaño/Rear support slat	360x50x15	01	263787	263787

Ferragens/Herrajes/Hardware



 *Usar os parafusos (G) para unir este módulo a outro. 
 Usar los tornillos (G) para unirse este módulo a otro.
 Use the screws (G) to join this module to another.

 *** Em caso de aquisição do tampo e roda tampo ***
 Este kit de ferragem possui 08 unidades a mais do parafuso (C) e 4 unidades do item (H). 



Medidas em mm
 Measures in mm
 Medidas en mm

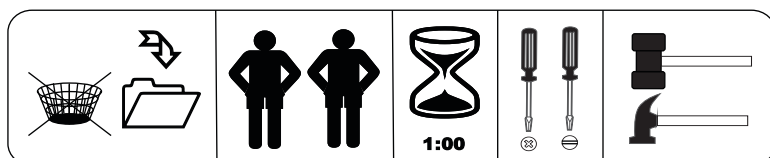

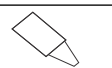
 **Giz para madeira** Produto para ser aplicado em caso de riscos na superfície.

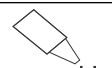
 **Giz para madeira** Product to be applied in case of scratches on the surface.

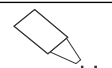
 **Giz para madeira** Producto para ser aplicado en caso de rayas en la superficie.

Pré-Montagem/Preparación Piezas/ Pre-assembly

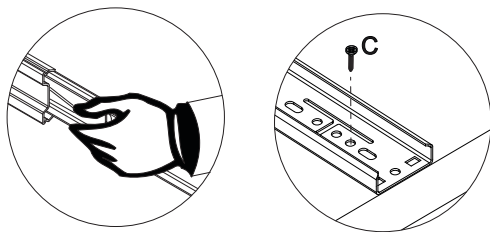

Soltar as partes da correição
 Afloje las piezas deslizantes
 Loosen the slide parts

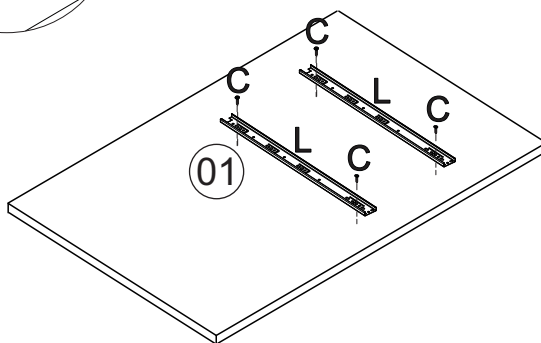

OBS: As correições telescópicas na lateral interna do balcão são fixadas, após a união da lateral interna com a base interna.

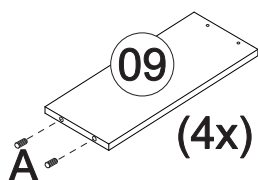
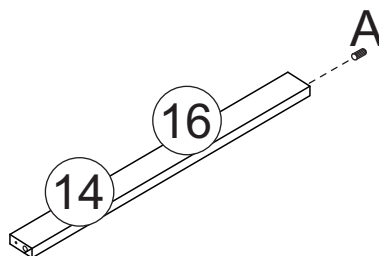

(4x)

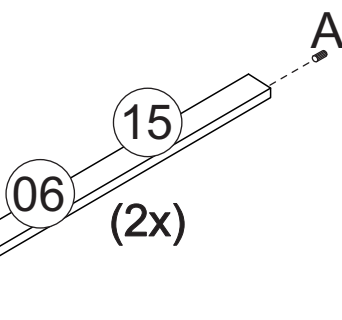

(2x)

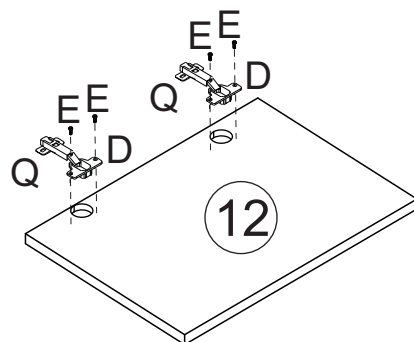

Utilizar cola nas cavilhas
 Usa pegamento en los tacos.
 Use glue on the dowels

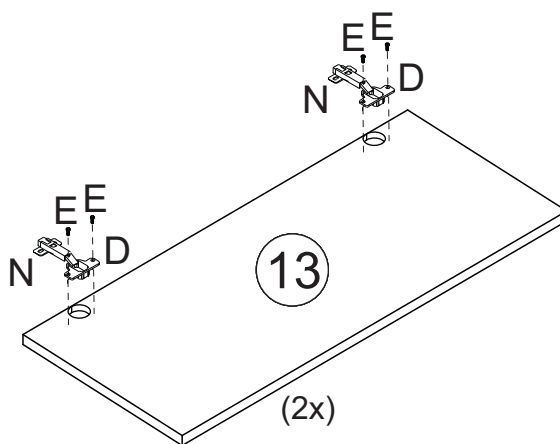

(2x)

01 Montagem/Montaje/Assembly

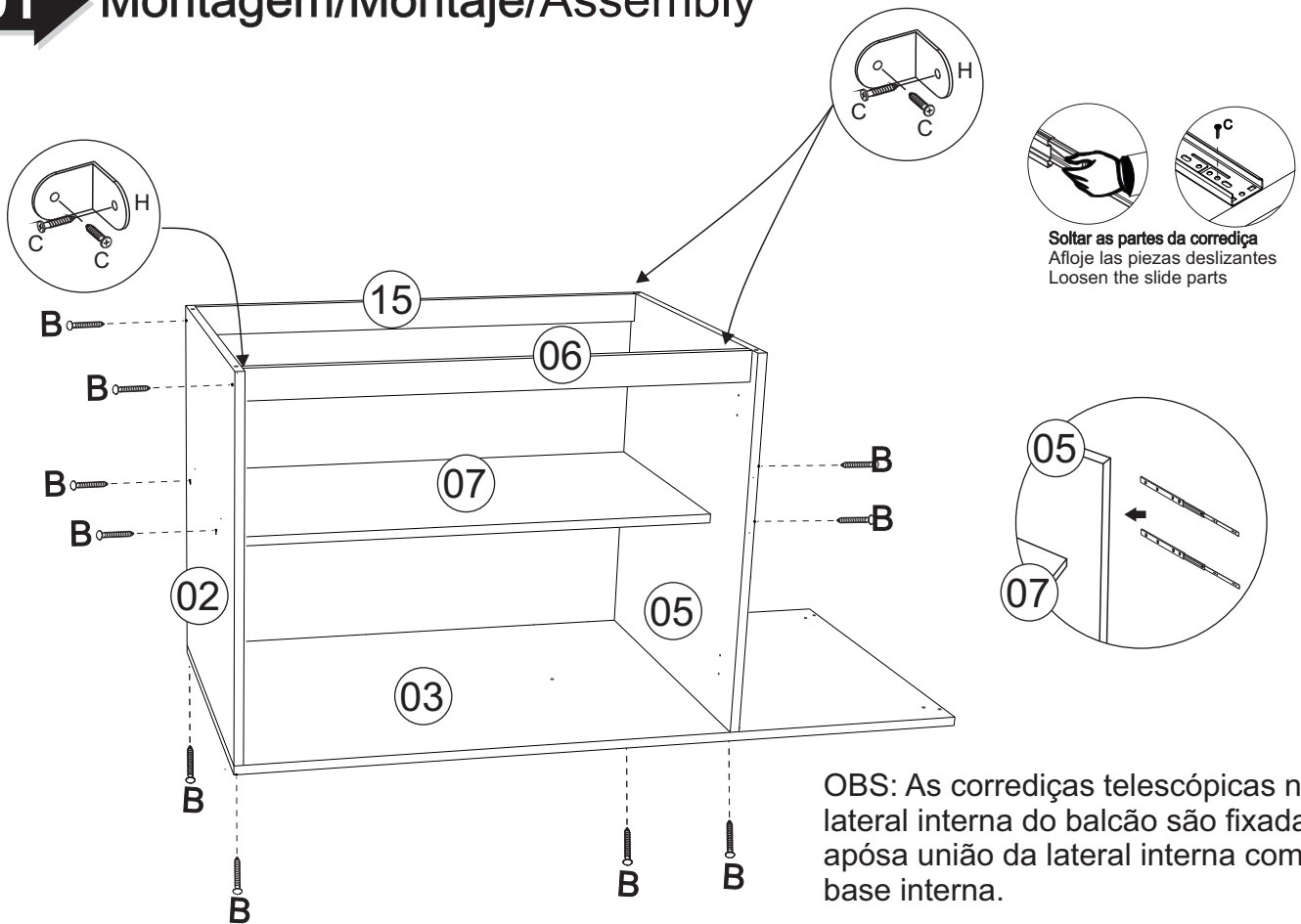

02 Montagem/Montaje/Assembly

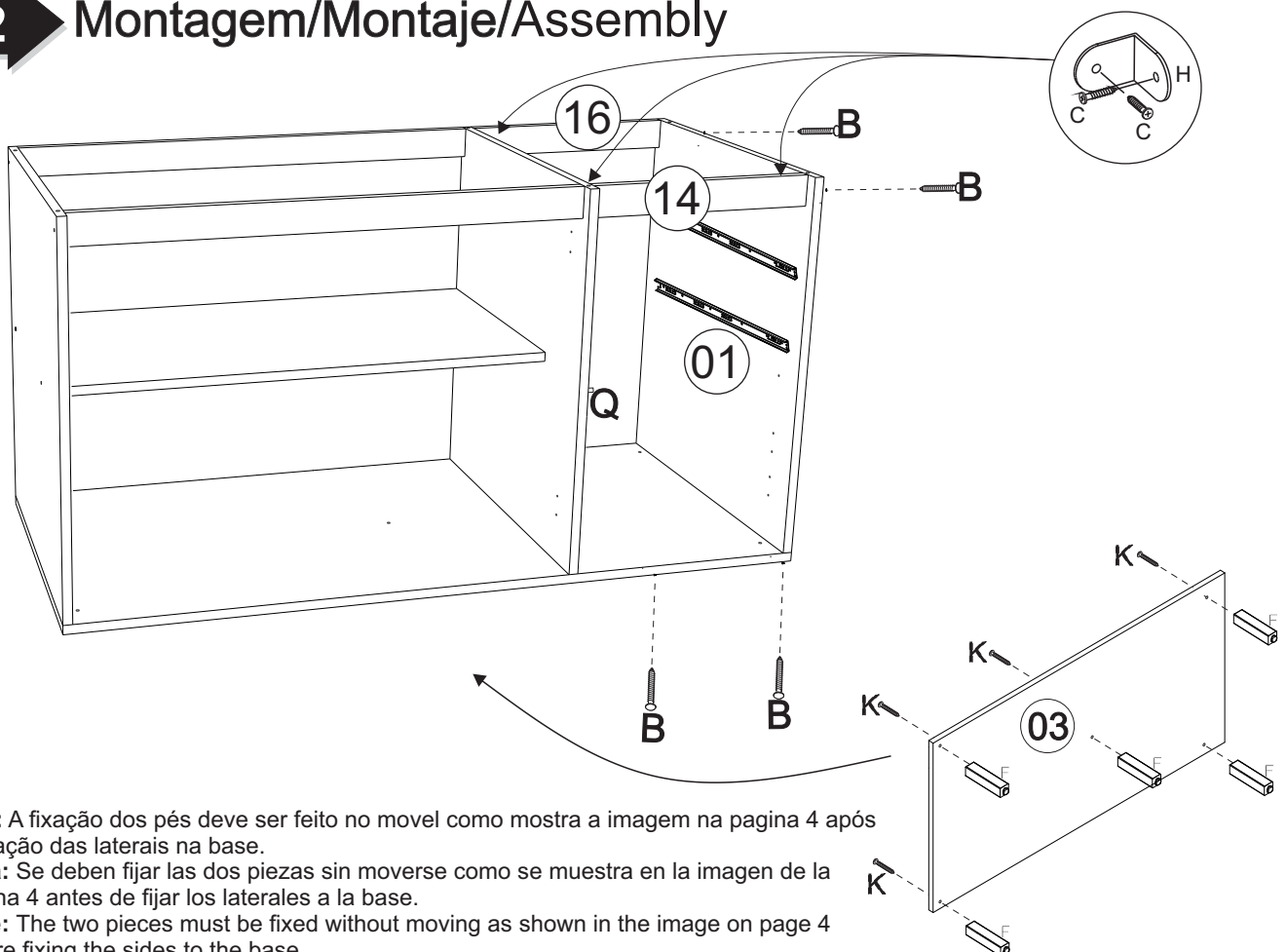

03 Montagem/Montaje/Assembly

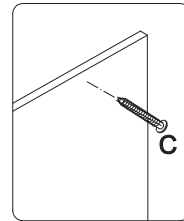
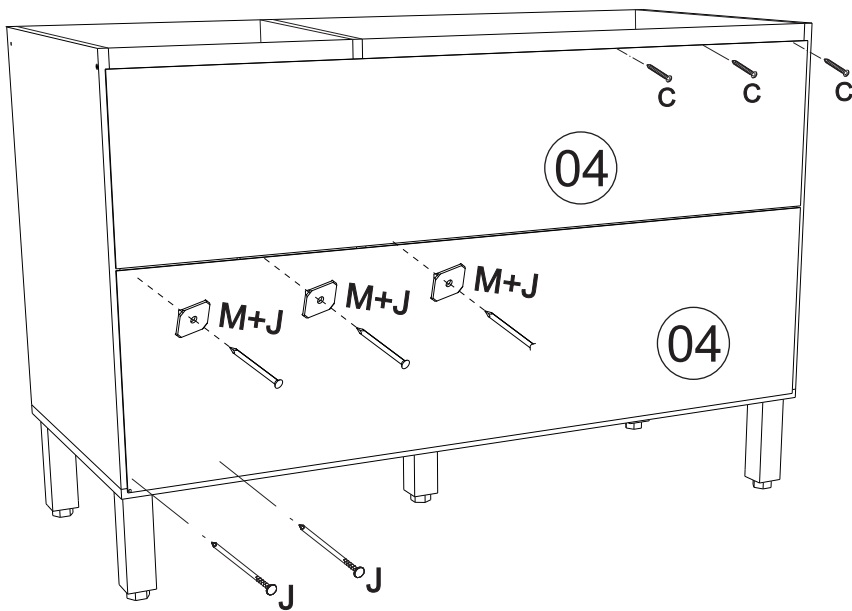

*Colocar um parafuso (C) a cada 100mm
*Colocar un tornillo (C) cada 100mm
*Place a screw (C) every 100mm

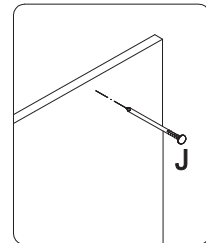

*Colocar um prego (J) a cada 100mm
*Colocar un clavo (J) cada 100mm
*Place a nail every (J) 100mm

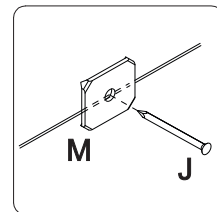

*Usar o prego (J) e a junção (M) a cada 100mm
*Usar el clavo (J) y la junta (M) cada 100mm
*Use the nail (J) and the joint (M) every 100mm

04 Montagem/Montaje/Assembly

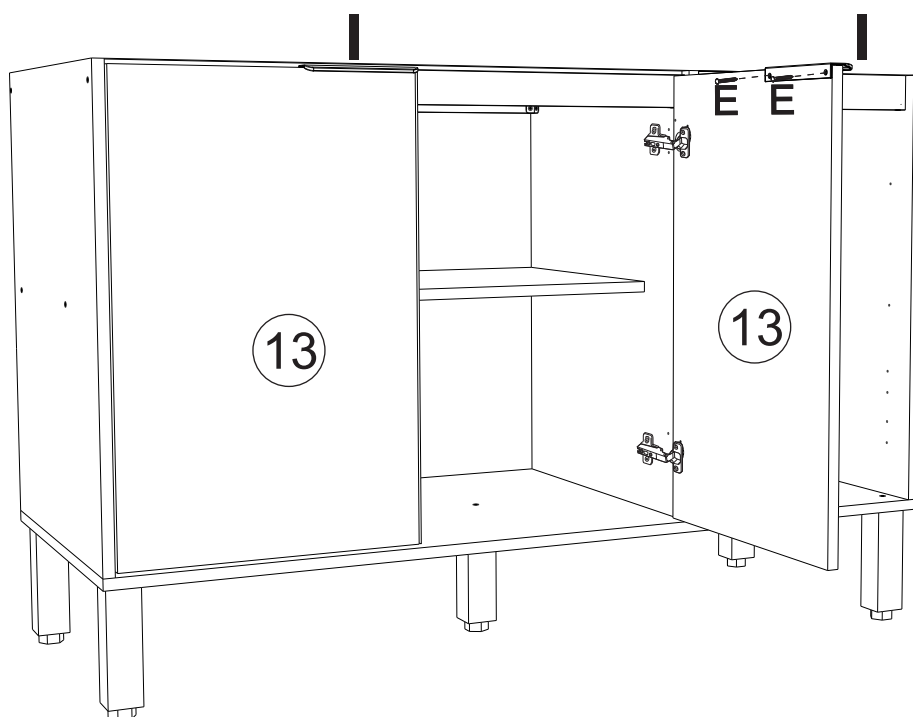

05 Montagem/Montaje/Assembly

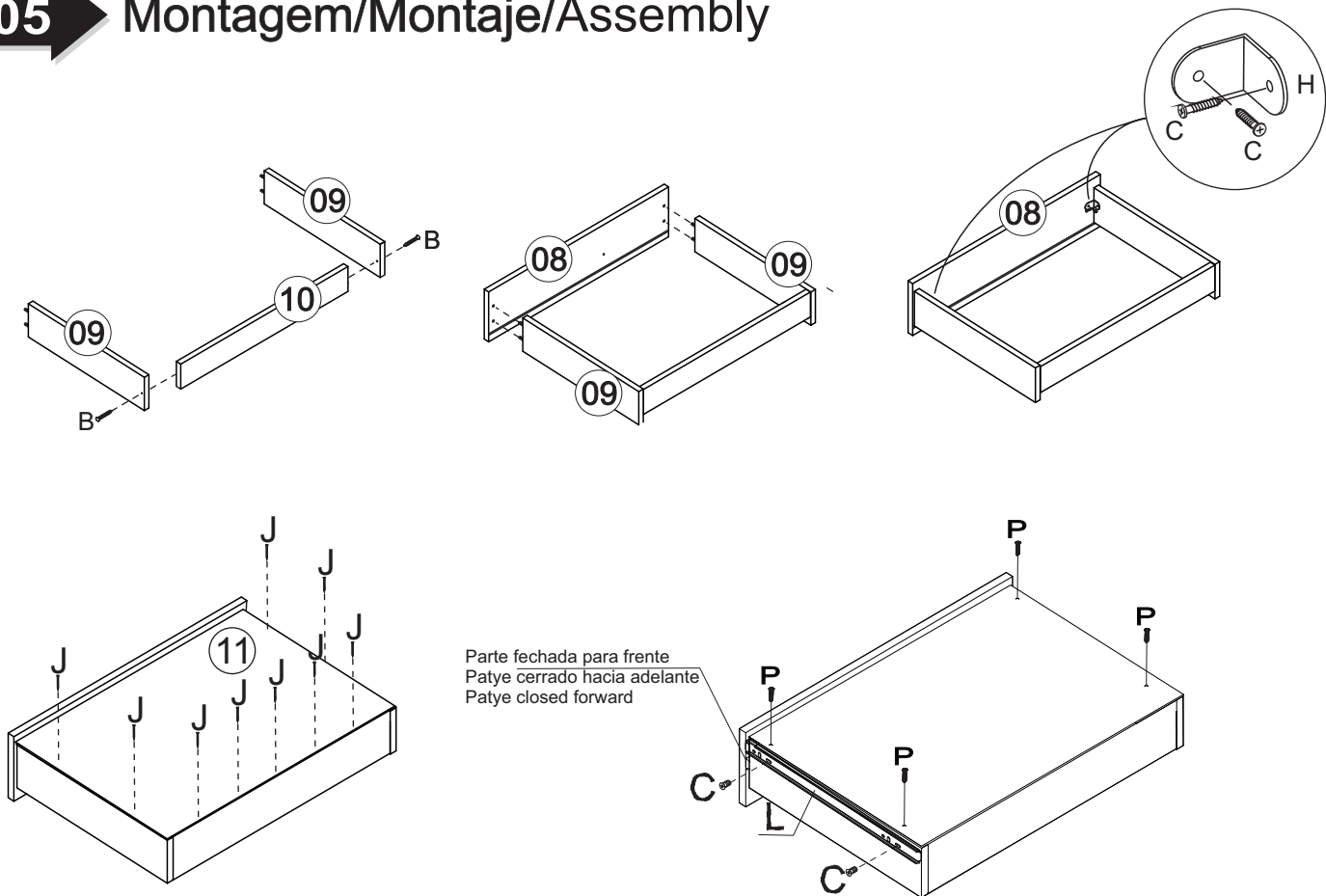

06 Montagem/Montaje/Assembly

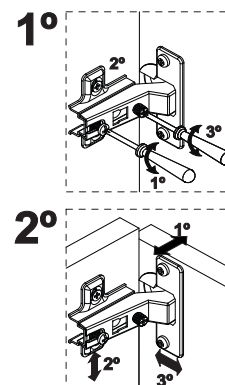
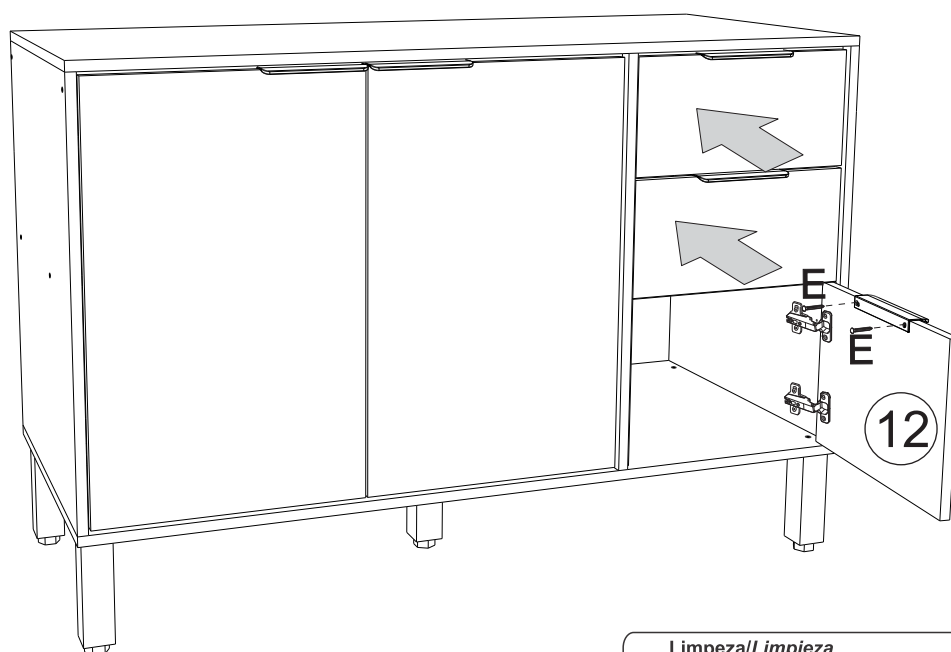

Limpeza/Limpieza

- ≠ Use um pano levemente umedecido com água, seguido de pano seco.
- ≠ Use solamente un paño húmedo con agua y después un paño seco.
- ≠ Use a cloth slightly dampened with water, followed by a dry cloth.
- ≠ Nunca utilize produtos químicos ou abrasivos.
- ≠ No utilice productos químicos o abrasivos.
- ≠ Never use chemical or abrasive products.